

ITEM NO.	QTY.	PART NO.	DESCRIPTION
1	1	744-936-20	FWM-8X BK MULTILITE SUB-ASSY W/LIGHTWAVE LOGO
2	1	10-7852	KIT, CABLE MANAGEMENT
3	1	10-4435	CARTON FRM PLAIN
4	1	10-5760	FRM MULTISCORE INSERT
5	4	960-045-10	INSERT CORNER 4 X 3 X 8 FRM ENCL

REV.	ECN #	DESCRIPTION OF CHANGE	DATE	BY	MFG ENG
01	N/A	INITIAL RELEASE	07/17/09	SAB	
02	1887	ADD ITEMS 4, 5, UPD VIEWS NOTES	09/30/09	SAB	
02	N/A	UPDATED PACKAGING NOTES	10/28/09	JR	
02	N/A	UPDATED ITEM #1 DESC.	05/20/10	L.P.K.	

NOTES:

1. PLACE ITEM #5 INSIDE OF ITEM #3 AS SHOWN.
2. PLACE ITEM #1 INSIDE OF ITEM #3 SUCH THAT IT IS SUPPORTED BY ITEM #5.
3. USE PACKING FOAM (NOT SHOWN) TO FILL IN AROUND ITEM #1 AS REQUIRED.
4. PLACE ITEM #2 INSIDE ITEM #4.
5. PLACE ITEM #4 ON TOP OF ITEM #1.
6. CLOSE ITEM #3 AND TAPE SHUT.
7. ONLY USE CUSTOMER APPROVED LABEL ON CARTON.

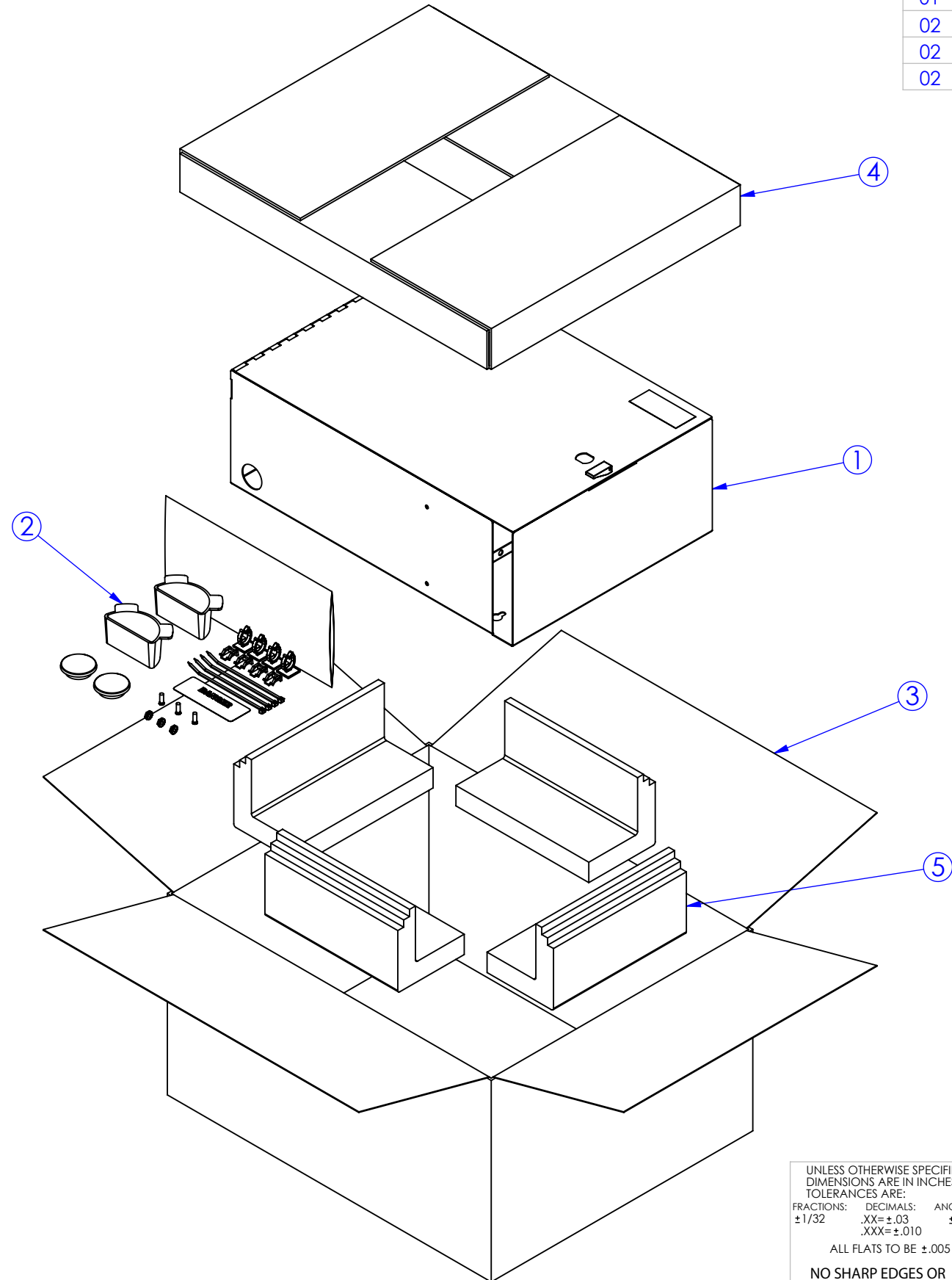

MOUNTING CONFIG

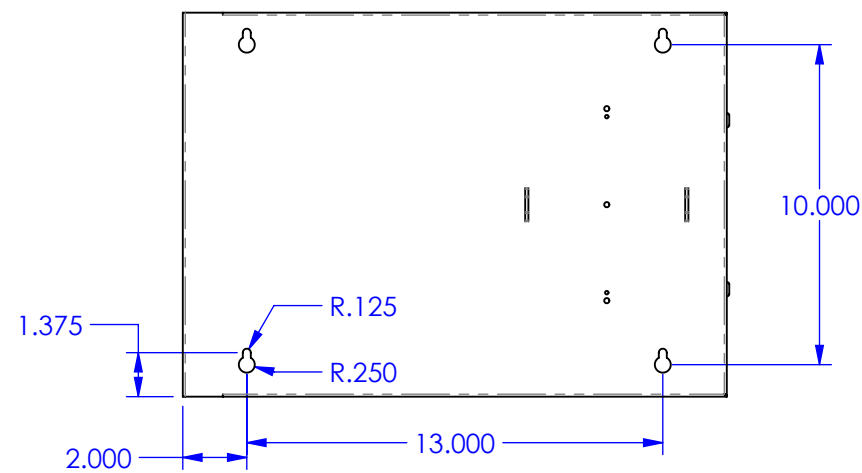

UNLESS OTHERWISE SPECIFIED  
DIMENSIONS ARE IN INCHES  
TOLERANCES ARE:  
FRACTIONS: DECIMALS: ANGLES:  
± 1/32 .XX = ± .03 ± 1°  
.XXX = ± .010

ALL FLATS TO BE ± .005

**NO SHARP EDGES OR  
BURRS ALLOWED**

MATERIAL:  
**SEE B.O.M.**

FINISH:  
**BLACK TEXTURED**

DO NOT SCALE DRAWING

DRAWN BY:	DATE:
CHECKED:	DATE:
MFG ENG:	DATE:
QUALITY ENG:	DATE:



LightWave Manufacturing & Services LLC  
2111-B Spencer Road | Richmond, VA 23230 | (804) 672-8426  
www.lightwavecable.com

SIZE <b>B</b>	DWG. NO. <b>WAC-8X</b>	REV. <b>02</b>
SCALE: 1:6	CAD FILE:	SHEET: 1